

Technical specifications
(1/3)

MMS 1963

By Miguel Milá



Mobles114

Technical specifications

(2/3)

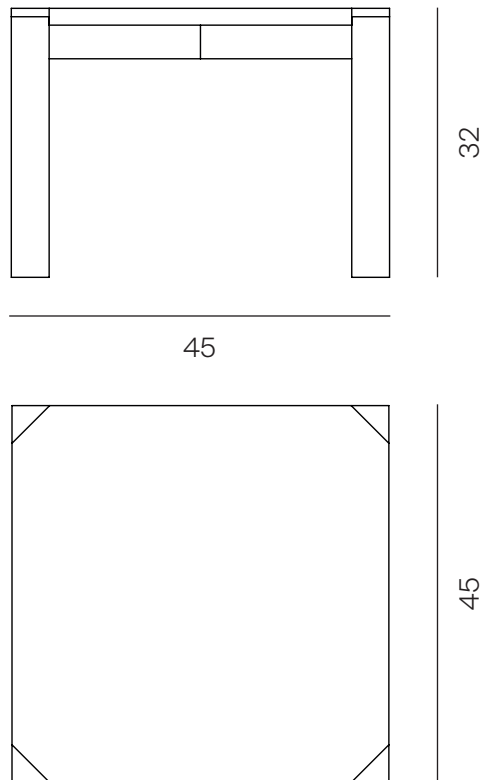

*Metric unit cm

PRODUCT

Units	Weight
1	6,5 kg

PACKAGING

Units	Weight	Dimensions	Volume
1	6 kg	52x52x40 cm	0,10 m ³

All packaging is made of double cardboard box, 100%

MATERIALS AND COLORS

Wood



Oak

Technical specifications

(3/3)

CERTIFICATIONS AND REGULATIONS

Wood: PEFC 10-34-142

MATERIALS AND FINISHES

Table formed by:

The top made of 20 mm thick oak plywood and 4 solid oak legs in a triangular shape, which are attached to a cross of the same material.

The structure of the legs and the cross is 10 mm below the top, in order to be able to mount one table with the other.

All the pieces are glued together, ensuring a correct settlement and an adequate position between them.

The glue used is from the d-2 effort group according to DIN EN-204 regulations. Subsequently, the entire table is varnished with water-based varnish. The procedure is scrubbing and refining the piece, two base coats, with scrubbing between the two coats and a final coat of water-based varnish.

With this we preserve the table from the action of atmospheric agents, also gaining physical and chemical resistance.

Note: Due to the fact that the wood used is natural, the finish may suffer variations in colour, tone and drawing.

MAINTENANCE

Clean with a damp cloth with mild soap and water. Rinse and dry with a dry cloth. Avoid using abrasive products.