

Technical specifications  
(1/3)

# Luco

By Martín Azúa



**Mobles14**

# Technical specifications

(2/3)

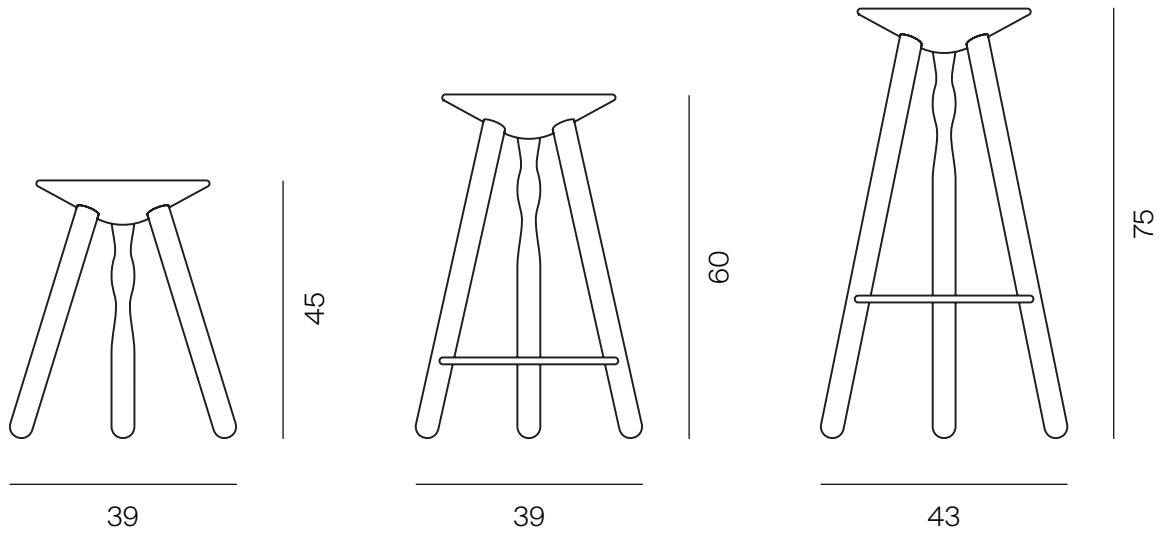

\*Metric unit: cm

## PRODUCT

	Units	Weight
Luco 45	1	2,5 kg
Luco 60	1	3,5 kg
Luco 75	1	4,5 kg

## PACKAGING

	Units	Weight	Dimensions	Volume
Luco 45	1	4 kg	42X43X49 cm	0,09 m <sup>3</sup>
Luco 60	1	5,5 kg	47X48X80 cm	0,18 m <sup>3</sup>
Luco 75	1	6 kg	47X48X80 cm	0,18 m <sup>3</sup>

All packaging is made of double recyclable cardboard.

## MATERIALS AND COLORS

### Structure (wood)



Beech

### Footrest (steel)



RAL 9004

# Technical specifications

(3/3)

## CERTIFICATIONS AND REGULATIONS

**Wood:** Forest Stewardship Council (FSC)

**Resistance in public use:** UNE-EN 16139:2013 level 2

## MATERIALS AND FINISHES

The seat and 3 feet are made of solid beech wood. Elements moulded on a lathe and then machined in numerical control to achieve perfect integration of the elements.

The four pieces are glued together to ensure correct positioning. The glue used is of the effort group d-2 according to DIN EN-204 standard.

Varnishing with water-based varnish, without colouring, to preserve the natural colour of the wood. The procedure is scrubbing, two coats of primer and a final coat of water-based varnish. This protects the armchair from atmospheric agents, and also provides physical and chemical resistance.

The 75 cm and 60 cm high models have a footrest. It is a "T" shaped element, made of 14 mm and 12 mm diameter steel rod, finished with a cataphoresis treatment and 80 micron 30% matt epoxy powder paint, RAL 9004 black colour. This element is attached to the wooden legs by means of 3 DIN 7991 M8 screws.

## MAINTENANCE

Clean with a damp cloth with mild soap and water. Rinse and dry with a dry cloth. Avoid using abrasive products.