

Technical specifications
(1/5)

Gràcia writing table

By JM Massana - JMTremoleda



Mobles114

Technical specifications

(2/5)

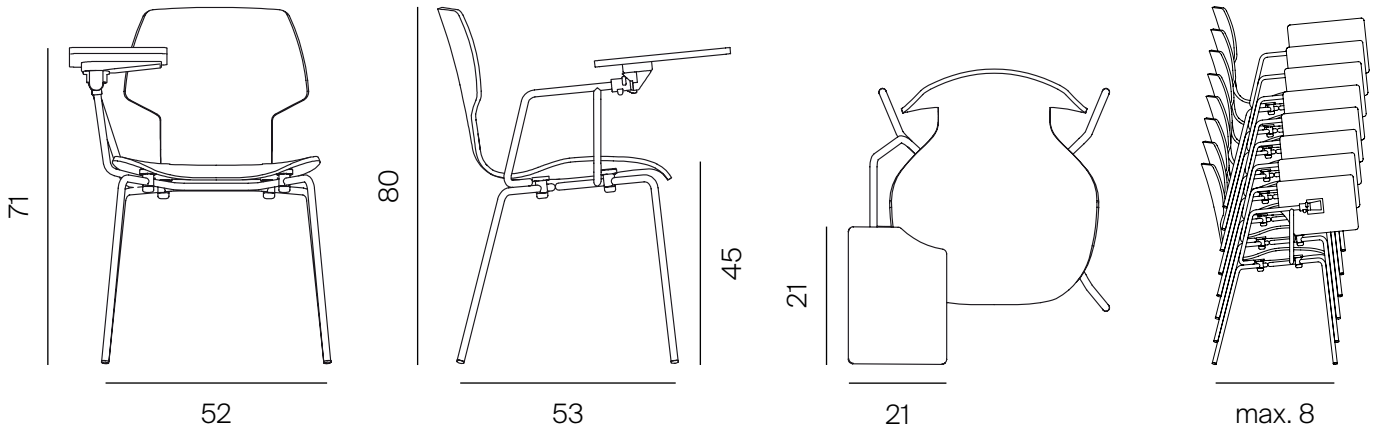

*Metric unit cm

PRODUCT

| Units | Weight |
|-------|--------|
| 1 | 7,5 kg |

PACKAGING

| Units | Weight | Dimensions | Volume |
|-------|--------|-------------|---------------------|
| 1 | 8,5 kg | 66x56x96 cm | 0,35 m ³ |

All packaging is double recyclable cardboard.

MATERIALS AND COLORS

Structure(steel)



RAL 9002 RAL 9004 Chromed

Seat (wood)



Oak Walnut

Writing table (HPL)

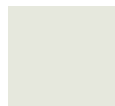

RAL 9002

Cushion (polyurethane)



RAL 9002 RAL 7022 RAL 6003 RAL 2001

Cushion (upholstered)



Dark Grey 60021 Brown 61103 Light Grey 61104 Terracotta 61151 Mustard 62057 Green 68165

Technical specifications

(3/5)

CERTIFICATIONS AND REGULATIONS

Fire retardant: UNE-EN 1021-1 y UNE-EN 1021-2

Resistance in public use: UNE-EN 15373:07

Resistance in domestic use: UNE-EN 1728:01

Wood: Forest Stewardship Council (FSC)

MATERIALS AND FINISHES

Structure

Structure made up of 2 curved section steel tubes 16x2mm. Front legs and rear legs are welded between them by the central area, giving the whole the resistance necessary. The arm of the writing table is made from the same tube and is welded either to the right or to the left depending on the model of the chair.

Structure finished in shiny chrome or in paint 80 micron epoxy powder, 30% textured matt in RAL white 9002 or black RAL 9004.

The 4 ground support points are protected with stops plastic in the same color as the structure.

Writing table

The writing support is made of white compact HPL laminate with a black core and a thickness of 8 mm. The swivel mechanism of the writing tablet is a standard part that is fixed to the structure with specific screws. It has an antipanic system that allows for easy exit from the chair.

Seat

Casing made of curved wood made up of 9 sheets beech 1.2 mm thick inside, and 2 sheets of oak or 0.6 mm walnut on the outside. All of them contrasting and adhered add up to a total of 12 mm thickness. Finished with water-based varnish. The bottom of the seat includes 4 M5 inserts, to be able to insert the clamping parts of the structure.

Anchoring pieces

The shell and legs are attached with a set of anchors. Anchor base: has the function of covering the threaded insert protruding from the seat shell.

Anchorage: fixes the structure with the casing. This part is attached to the insert with a zinc plated DIN 7380 M5X16 allen screw.

Elements made of polyamide PA6 finished in white RAL 9002 or black RAL 9004.

Folding chair (Max. 8)

ACCESSORIES

Cushion

Optionally, it can take a cushion made of polyurethane foam injection (PUR). In order for it to be correctly positioned, this piece is attached to the chair with cyanoacrylate glue.

The cushion is available in different colors: anthracite gray RAL 7022, green RAL 6003, white RAL 9002 or orange RAL 2001, or upholstered with the different fabrics from the Mobles114 catalog.

FABRIC Gabriel Cura

Technical specifications:

Material: Post - costumer recycled polyester · polyester 98% · 2%
Weight: 420 g/lm · (13.55 oz/lin.yd.)

Width: 140 cm · (55")

Abrasion resistance: Rubs · BS EN 14465 · BS EN ISO 12947-2 (Martindale) 100,000. Double rubs wyzenbeek (ASTM D4157) (Heavy Duty Upholstery) 100,000

Pilling: Scale 1-5 max. 5 · EN ISO 12945-2

Maintenance: Wash or dry cleaning. Flame retardant performance is dependent upon the foam used. Contain no Flame Retardant chemical.

Flammability: EN 1021 1&2 · BS 5852 0&1 · CA TB 117 - 2013

Will also pass other flammability standards.

40°C · Shrinkage max. 1,0%

60°C · Shrinkage max. 2,0%

FABRIC Spardling Valencia

Technical specifications:

Material: Vinyl / Urethane

Weight: 650 g/m²

Width: 137 cm · (53")

Abrasion resistance: >300.000 cycled (Martindale)

Pilling: Scale 1-5 max. 5 · EN ISO 12945 - 2

Maintenance: For light soiling, a solution of 10% household liquid dishsoap in warm water, applied with a soft damp cloth. Rinse with clean water and dry. Do not use with alcohol based cleaning agents.

Flammability: EN: 1021 1&2 · ES: UNE 23.727-90 1R/M.2 · FR: NF P 92-503/M2 DE: DIN 4102 B2 · AT: ÖNORM B 3825, Gruppe 1 - Schwerbrennbares IT: UNI 9175 (1987) / UNI 9175/FA1 (1994) Classe 1.IM (UNO I EMME) AT: ÖNORM A 3800 Teil 1, Qualmbildungsklasse Q1 - schwachqualmend IMO FTP 2010 Code MSC.307 (88) Part 8 3.1 & 3.2 · US: FMVSS 302 US: FAR 25/853 · ECE R118.02 (replaces Directive 95/28/CE) 6, 7 & 8 EN 71-2:2006+A1:2007 - Safety of Toys - Parte 2: Flammability

Technical specifications

(4/5)

FABRIC Gabriel Step

Características técnicas:

Material: Trevira CS 100%

Peso: 470 g/lm · (15.16 oz/lin.yd.)

Ancho: 140 cm · (55")

Resistencia a la abrasión: Rubs · EN ISO 12947-2 (Martindale) 100,000 Double rubs wyzenbeek (ASTM D4157-07) (Heavy duty upholstery) 100,000.

Frisado: Scale 1-5 max. 5 · EN ISO 12945 - 2

Maintenance: Mantenimiento: Lavado o limpieza en seco. Se puede limpiar con Virkon S, Acticlolor Plus, Prime Source ren 93 o Etanol (70-85%). Siempre siga las instrucciones del fabricante y termine limpiando con un paño húmedo. 60°C · Contracción máx. 3,0% / 74°C · Contracción máx. 5,0%

Inflamabilidad: CA TB 117 - 2013 BS 7176 Medium Hazard. AM 18 - NF D 60-013-(only for fabric) · DIN 4102 B1 · NFP 92-503/504/505 M1. BS EN 1021 1&2 · BS 5852 Part 1 0,1 Cigarette & match · BS 5852 Crib 5. Class Uno UNI 9175 Class 1 | EMME · ÖNORM B 3825 - B1 - 3800 - Q1 UK. FAR/JAR 25.853 (a) (i) (ii) · IMO MSC 307(88) Anne x 1 part 8. MED Certificate IMO · DIN EN 13501 - 1 B-s1, d0. También pasará otras normas de inflamabilidad. Retardante de llama performance is dependent upon the foam used.

TELA Gabriel Step Melange

Technical specifications:

Material: Trevira CS 100%

Weight: 470 g/lm · (15.16 oz/lin.yd.)

Width: 140 cm · (55")

Abrasion resistance: Rubs · EN ISO 12947-2 (Martindale) 100,000 Double rubs wyzenbeek (ASTM D4157-07) (Heavy duty upholstery) 100,000.

Pilling: Scale 1-5 max. 5 · EN ISO 12945 - 2

Maintenance: Wash or dry cleaning. Can be wiped with Virkon S, Actichlor Plus, Prime Source ren 93 or Ethanol (70-85%). Always follow the manufacturer's instructions and finish by wiping with a damp cloth. 60°C · Shrinkage max. 3,0% / 74°C · Shrinkage max. 5,0%

Flammability: CA TB 117 - 2013 BS 7176 Medium Hazard. AM 18 - NF D 60-013-(only for fabric) · DIN 4102 B1 · NFP 92-503/504/505 M1. BS EN 1021 1&2 · BS 5852 Part 1 0,1 Cigarette & match · BS 5852 Crib 5. Class Uno UNI 9175 Class 1 | EMME · ÖNORM B 3825 - B1 - 3800 - Q1 UK. FAR/JAR 25.853 (a) (i) (ii) · IMO MSC 307(88) Anne x 1 part 8. MED Certificate IMO · DIN EN 13501 - 1 B-s1, d0.

Will also pass other flammability standards. Flame retardant performance is dependent upon the foam used.

FABRIC Gabriel Capture

Technical specifications:

Material: New Zealand wool · polyamide 85% · 15%

Weight: 475 g/lm 3 (15.32 oz/lin.yd.)

Width: 140 cm · (55")

Abrasion resistance: Rubs · BS EN 14465 · BS EN ISO 12947 - 2 (Martindale) rubs 200,000. Martindale · ASTM D4966 - 02 (Heavy Duty Upholstery) 200,000

Pilling: Scale 1-5 max. 5 · EN ISO 12945 - 2

Maintenance: Dry cleaning

Flammability: EN 1021 1&2 · BS 5852 0&1 · CA TB 117 - 2013. Class Uno UNI 9175 Class 1 | EMME

Will also pass other flammability standards. Flame retardant performance is dependent upon the foam used. Contain no Flame Retardant chemical.

FABRIC Kvadrat Remix 2

Technical specifications:

Material: New wool · Nylon 90% · 10%

Weight: 415 g/lm · (14.63 oz/lin.yd.)

Width: 138 cm · (54")

Abrasion resistance: Rubs · EN ISO 12947 (Martindale) 100.000

Pilling: Note 4, EN ISO 12945

Maintenance: Vacuuming and dry cleaning

Flammability: AS/NZS 1530.3 · BS 5852 Crib 5 with treatment · BS 5852 part 1. EN 1021-1/2 · IMO FTP Code 2010: Part 8 · NF D 60 013 · NFPA 260. Önorm B1/Q1 · UNI 9175 1M · US Cal. Bull. 117-2013.

No use of brominated flame retardants.

FABRIC Kvadrat Divina Melange

Technical specifications:

Material: New wool 100%

Weight: 820 g/lin.m

Width: 150 cm · (59")

Abrasion resistance: Rubs · EN ISO 12947 (Martindale) 45.000

Pilling: Note 3, EN ISO 12945

Maintenance: Vacuuming and dry cleaning

Flammability: AS/NZS 1530.3, BS 5852 Crib 5, BS 5852 ignition source 3, BS 5852 part 1, BS 5867 part 2 type B, EN 1021-1/2, EN 13501, C-s1, d0, glued, NF D 60 013, NFPA 260, SN 198 898 5.3 with treatment *, UNI 9175 1M, US Cal. Bull. 117-2013, ÖNORM B1/Q1

FABRIC Kvadrat Steelcut Trio 3

Technical specifications:

Material: New wool · Nylon 90% · 10%

Weight: 770 g/lm · (27,16 oz/lin.yd.)

Width: 140 cm · (55")

Abrasion resistance: rubs · EN ISO 12947 (Martindale) 100.000

Pilling: Note 4, EN ISO 12945

Maintenance: Vacuuming and dry cleaning

Flammability: AS/NZS 1530.3 · AS/NZS 3837 class 2 · BS 5852 Crib 5 with treatment BS 5852 part 1 · DIN 4102 B2 · EN 1021-1/2 · IMO FTP Code 2010: Part 8 NF D 60 013 · NFPA 260 · Önorm B1/Q1 · SN 198 898 5.3 with treatment UNI 9175 1M · US Cal. Bull. 117-2013

No use of brominated flameretardants

Technical specifications

(5/5)

Joining clamp

Joining clamp between chairs made of polypropylene (PP). Pinça d'unió entre cadires fabricada en polipropilè (PP).

Platform for transporting chairs

Steel platform to transport 8 stackable chairs. General dimensions: 540x540x140 mm (including wheels). Structure made from 4 steel plates, L section 45x2 mm in diameter. Internally tooled with M10 thread to position the wheels.

Standard wheels, 50 mm diameter.
Maximum load: 48 kg per wheel.

The platform's base is made from HPL (High Pressure Laminate) using wood subproducts (cellulose) and thermosetting resin, 8 mm thick, hardwearing, durable and uniform.
Standard finish in white RAL 9002.

MAINTENANCE

Clean with a damp cloth with mild soap and water. Rinse and dry with a dry cloth. Avoid using abrasive products.