

Technical specifications
(1/3)

Jujol 1920

By Josep Maria Jujol



Mobles114

Technical specifications

(2/3)

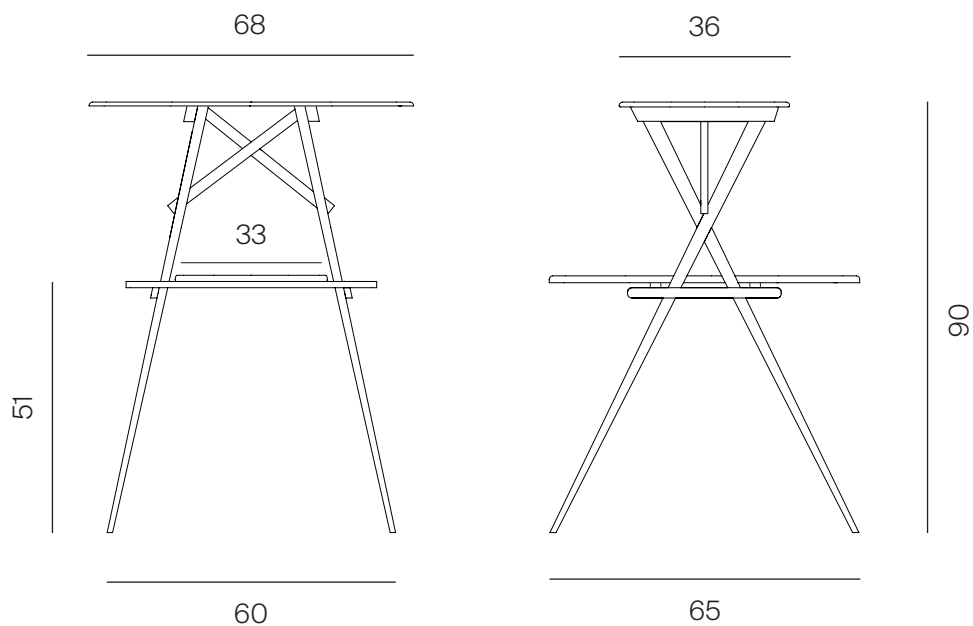

*Metric unit cm

PRODUCT

Units	Weight
1	6,5 kg

PACKAGING

Units	Weight	Dimensions	Volume
1	14 kg	80x76x95 cm	0,58 m ³

All packaging is made of double cardboard box, 100% recyclable.

MATERIALS AND COLORS

Wood



Oak

Technical specifications

(3/3)

CERTIFICATIONS AND REGULATIONS

Wood: PEFC 10-34-142

MATERIALS AND FINISHES

The production is handmade.

Made up of 4 different legs, braces and 2 oval-shaped tops, all in solid oak. All the pieces are joined together, with specific hardware and glue, ensuring correct stability and an adequate position of the elements.

The glue used is from group D-2, according to DIN EN-204 regulations. The finish of the piece is water-based varnish. Previously, the piece is polished and refined, then two base coats are applied with scrubbing between the two coats and a final coat of water-based varnish. With this we preserve the table from the action of atmospheric agents, also gaining physical and chemical resistance.

Set finished with water-based varnish, without dye. The procedure is scrubbed and refined, two base coats with a scrub between them and a last coat of water-based varnish. With this we preserve the table from the action of atmospheric agents, also gaining physical and chemical resistance.

Note: Due to the fact that the wood used is natural, the finish may suffer variations in colour, tone and drawing.

MAINTENANCE

Clean with a damp cloth with mild soap and water. Rinse and dry with a dry cloth. Avoid using abrasive products.